

UARA.305

4X4 Terrain Transmission (Dual Cycle – 4x4 Locked) (Pump Output)

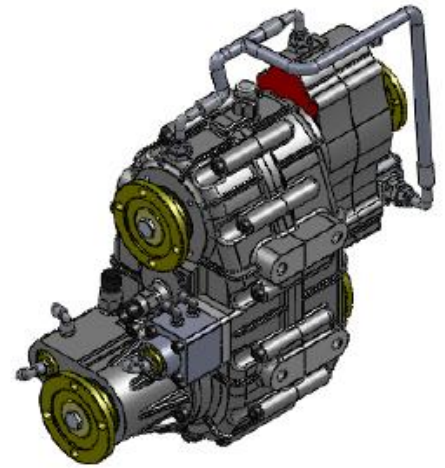

1. INTRODUCTION

The UARA.305 is a split shaft unit with double-action, produced for 4x4 terrain vehicles, with self-differential and the feature of locking this differential. While the vehicle may be driven at low and high gear, it doubles the number of available gears. Moreover, it has pump output feature to operate higher equipment.

2. TECHNICAL SPECIFICATIONS

The input flange of the split shaft unit is connected directly to the shaft from the main transmission, and transmits motion to both the front and the rear differential through the bottom outputs by increasing the driving torque of the vehicle. It is capable of transforming available 4x2 vehicles to 4x4 by the addition of the front differential equipment.

The differential, with its feature of being locked, ensures moving forward without spinning, by equalizing the rotation moments of the shafts leading to the front and rear differential of the vehicle. However, it should not be used in this manner constantly.

It has the ability to use the pump output independently, while the vehicle is moving and is stopped.

It is possible to control the engaging-disengaging features of the split shaft unit by an electrical sensor.

3. ENGAGING-DISENGAGING

The split shaft unit engaging-disengaging allows the low-high drive position and the differential lock position through double-action pneumatic cylinder and 6-8 bar air pressure. The pump output control is provided by a single-action spring return pneumatic cylinder and 6-8 bar air pressure.

In addition, the backward drive system engaging-disengaging operation is made by the 6-8 bar double-action pneumatic cylinder. When this system is engaged, the low-high position of the split shaft unit must definitely be in neutral position and ensured to remain fixed. Precaution should be taken by a blocking system in order to prevent any opposite action on the engaging-disengaging control of the backward drive system.

4. TECHNICAL DATA

4.1. INPUT

Power (Max.)	: 178 KW
Torque (Max.)	: 1700 Nm-175 Kgm. (1000 rpm)
Rotation (Max.)	: 3000-3900 rpm
Weight	: 80 Kg.

4.2. DIFFERENTIAL OUTPUTS

Torque (Max.)	: 1700 Nm-175 Kgm. (1000 rpm)
Rotation Direction	: CCW (in the same direction with the drive shaft)
Rotation (Max.)	: 2500-3000 rpm
Ratio (Diff. Output)	: 1/0.257 (Low) — 1/0.85 (High)
Control Type	: Pneumatic

4.3. PUMP OUTPUT (OPTIONAL)

Torque	: 573 Nm-58 Kgm
Rotation Direction	: CCW (in the same direction with the drive shaft)
Rotation (Max.)	: 2500-3000 rpm
Ratio (Pump Output)	: 1/1
Control Type	: Pneumatic
Connection Type	: UNI, ISO, FLANGE

4.4. DIMENSIONS

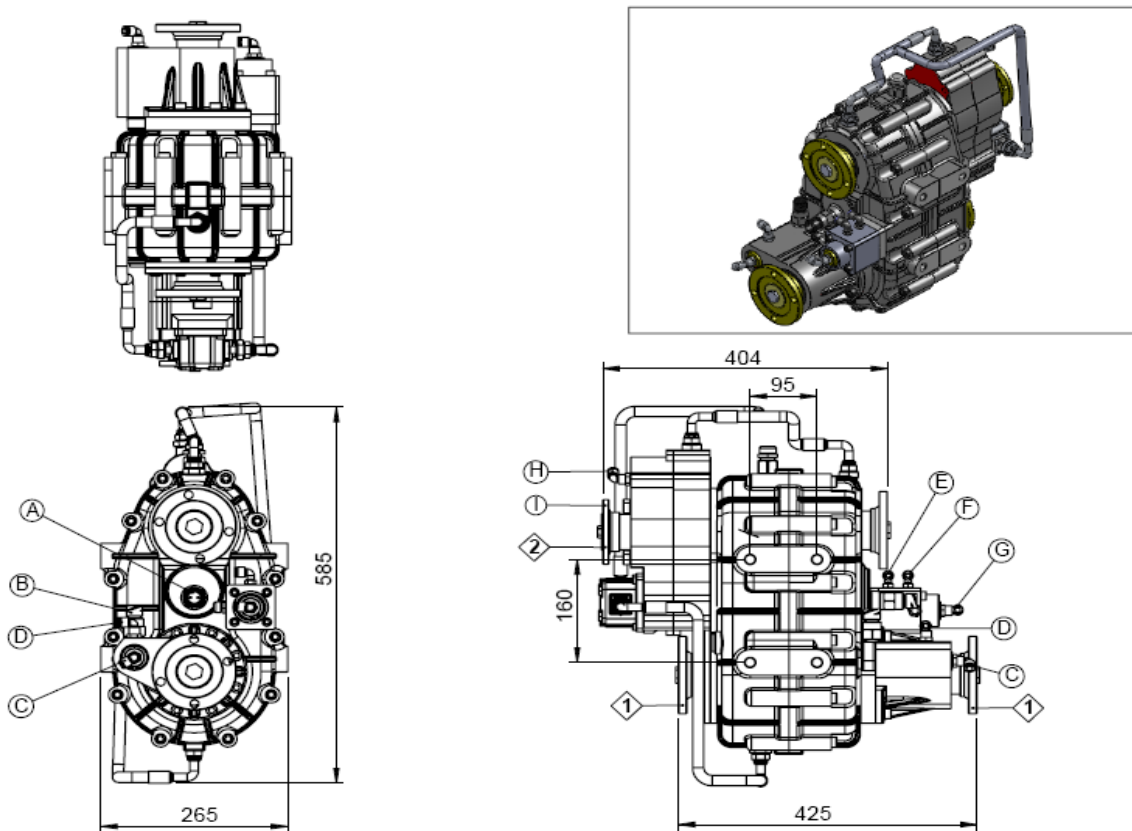

5. INSTALLATION

In the installation of the UARA.305 split shaft unit on the vehicle, the chassis should not be in direct contact with the split shaft unit, wedging should definitely be made between the connection apparatus and the chassis. The angle of the split shaft unit position connection shafts should be adjusted so as not to exceed 7° . In case this rule is not taken observed, there may be a knocking-type noise during the operation of the split shaft unit.

6. SERVICE-MAINTENANCE

6.1. OIL FILLING

The split shaft units are shipped as unoiled. Oil should be filled into the split shaft unit using the oil filling mechanism, before running the split shaft unit. The oil filling operation should be made on the ground. The correct oil level is the top level shown on the indicator. The oil should be totally clean. You are required to use only the recommended oil (75W80 or 80W90). In case of using any oil other than the recommended oil, the vehicle is out of warranty coverage.

6.2. Oil Level Control

The oil level should be checked by removing the oil level plug. Maintenance should be made on a weekly basis. Maintenance should be made before and after long trips.

Maintenance should be made at ground level and when the vehicle is not running. In case the oil level is less than required, oil should be added.

6.3. Oil replacement

First oil replacement should be made following 100 hours after the split shaft unit has started to run. Oil replacement should be made when the oil is hot. Draining may be made by removing the drain plug. In order to accelerate the process, it is recommended to remove the filling plug also. Before re-starting, the drain plug is required to be cleaned. Subsequent oil replacements should be made once in every 500 hours or once a year.

Important

During oil replacement, do not touch the hot oil. Act in compliance with the country legislations in the disposal of the waste oil. Do not pollute the environment.

6.4. Identification of Oil Leaks

Check for oil leaks periodically. Check for any oil leaks in the area where the vehicle is operated and the surroundings. In case of detecting any oil leaks, check the oil level. Replace the seals if necessary.

6.5. General Equipment Control

Control the equipment periodically. Check the installation equipment, transmission elements and the transmission casing. Re-tighten, if necessary.